

TECHNICAL DATA SHEET



PEDESTAL

EH 15

CODE
E000015000

REV 00
27.06.2013



EH 15 FIXED PEDESTAL

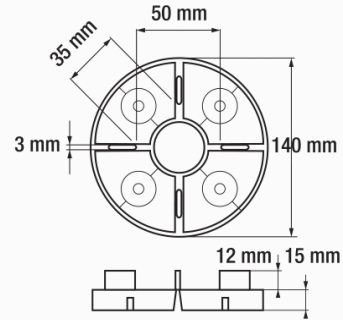

ITEM SPECIFICATION

EH fixed type pedestal for raised floors. Pedestals are composed by a unique element in polypropylene of 140mm diameter base for resting on the laying surface and of 15 mm high. On the upper part it is provided of 4 tabs of h.12 mm in 3 mm thickness. Base is provided of holes for water drainage.

PRODUCT RANGE

PEDESTAL

PRODUCT NAME

EH 15

CHARACTERISTICS

Fixed pedestal compatible with one or more balancers of 5mm highness. Easy breakable in 2, 3 or 4 parts in case of need for wall or internal or external corner application. Possibility of stack up maximum 2 fixed pedestals, also combining different highness.

RAW MATERIAL

Polypropylene

ENVIRONMENTAL IMPACT

recyclable material - non dangerous

APPLICATIONS SURFACES

On any waterproofing membrane, or any insulating panel or any compact and solid surface

APPLICATIONS AREA

Usable with any prefabricated self sustaining element for exterior flooring

CHARACTERISTICS	UNIT	VALUE	TOLERANCE
BASE DIAMETER	mm	140	+/- mm 1,0
BASE THICKNESS	mm		+/- mm 0,2
MINIMUM HEIGHTNESS	mm	15	+/- mm 1,0
TABS THICKNESS	mm	3	+/- mm 0,2
TABS HIGHNESS	mm	12	+/- mm 0,2
WEIGHT	kg	0,046	+/- 5 %

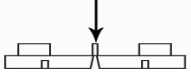
TECHNICAL PROPERTIES		UNIT	VALUE
CENTRAL COMPRESSION LOADING LIMIT RESISTANCE* <small>(calculated at medium highness, between minimum and maximum extension)</small>		KN	55,13
SHORE		Shore d	70 (+/- 3)

*Tests made by Civil and Environmental Department of University of Padova. 1 KN = 98,6 Ka

PHYSICAL PROPERTIES	METHOD	UNIT	VALUE
FIRE REACTION*	UNI EN 13501-1:2009	class	E
LOW TEMPERATURES REACTION			-40°

*Tests made by Giordano S.p.A. Institute of Bellaria-Iaeca Marina (RN)-Italy

PACKAGING AND STORAGE			
PIECES PER BOX			200
PIECES PER PALLET			20
BOX DIMENSION			cm 39,5x60x42,5
BOX WEIGHT			kg 10,20
PALLET DIMENSION			cm 80 x 120

The packing of the supports is made of boxes. The final pallets are wrapped with a polyethylene film. We recommend to store indoor, pallets to be protected from the rain.

LAYING OF THE PRODUCT	
	The product is simply laid on the laying area, with no need of any glue or fixing

The above data are relevant to current production and may be changed or updated by Eterno Ivica at any time without notice.

Given the many possible uses and the possible interference of external elements, we do not assume responsibility for the results. The buyer is required to establish under their own responsibility the suitability of the product for the intended use. This document is property of Eterno Ivica. All rights reserved.



Eterno Ivica srl - Via Austria 25/E - Z.I.Sud 35127 Padova - Italy
 T Exp. +39 049 8530102, T +39 049 8530101, F +39 049 8530111
 eternoivica@eternoivica.com - www.eternoivica.com

